

# GVU-12 NO2 MONITOR FIELD WIRING

## FIELD WIRING DIAGRAM

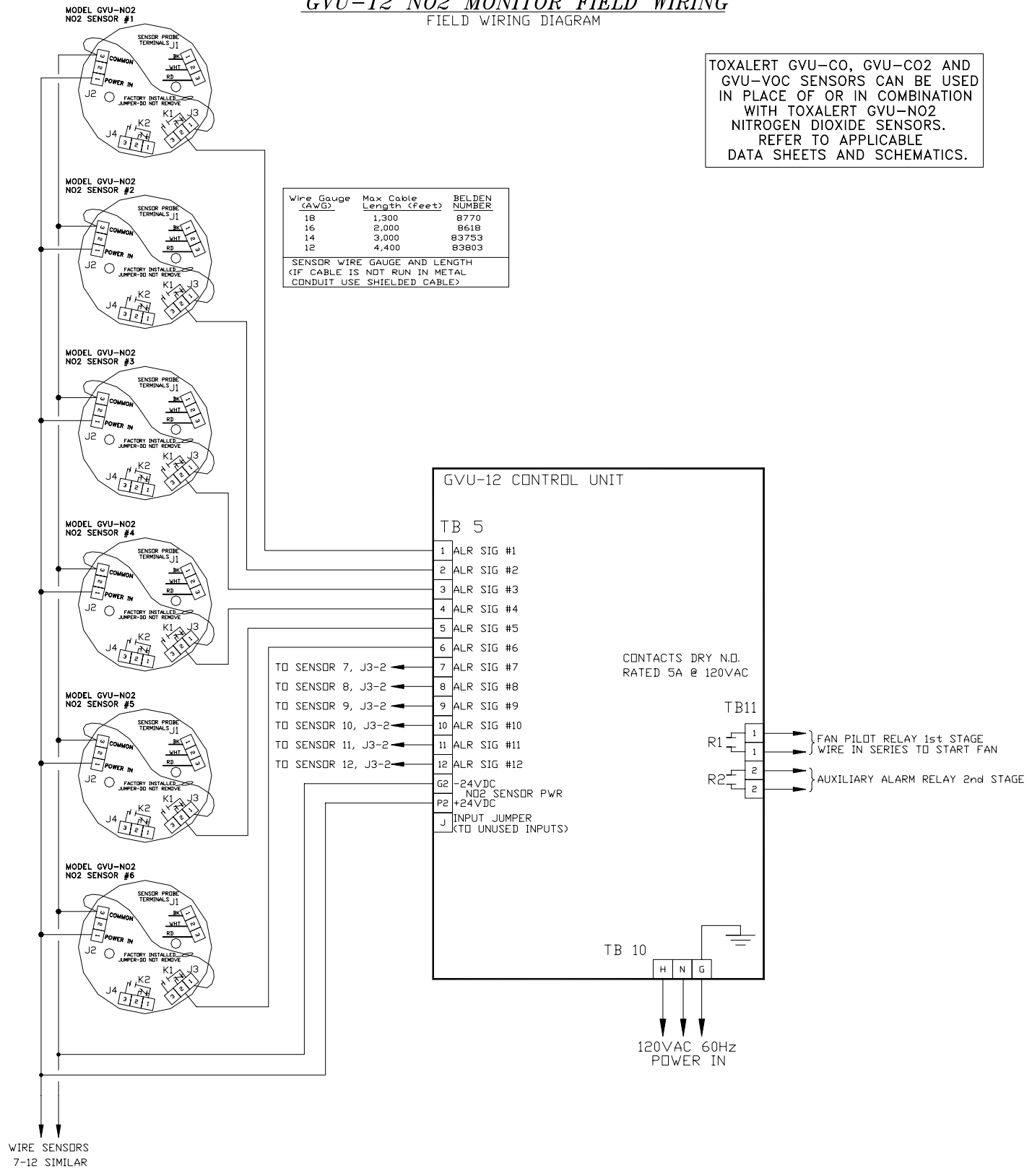

TOXALERT Gvu-CO, Gvu-CO2 AND Gvu-VOC SENSORS CAN BE USED IN PLACE OF OR IN COMBINATION WITH TOXALERT Gvu-NO2 NITROGEN DIOXIDE SENSORS. REFER TO APPLICABLE DATA SHEETS AND SCHEMATICS.

Wire Gauge (AWG)	Max Cable Length (feet)	BELDEN NUMBER
18	1,300	8770
16	2,000	8618
14	3,000	83753
12	4,400	83803

SENSOR WIRE GAUGE AND LENGTH (IF CABLE IS NOT RUN IN METAL CONDUIT USE SHIELDED CABLE)

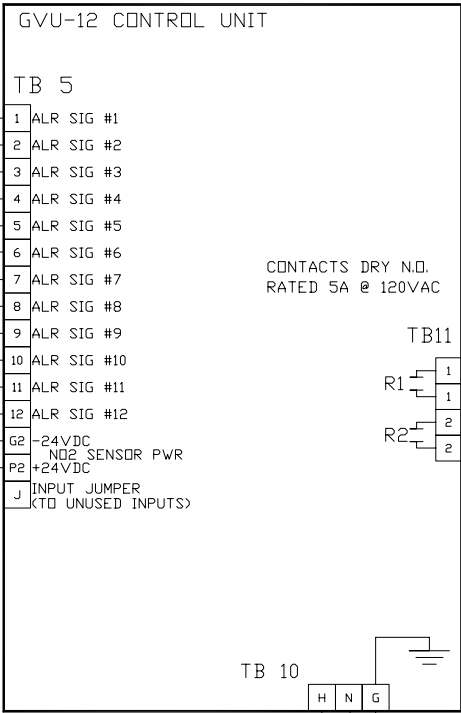

WIRE SENSORS  
7-12 SIMILAR

<b>TOXALERT</b> <b>INTERNATIONAL</b> GAS DETECTION SYSTEMS www.toxalert.com P.O. BOX 158 MOUND, MN. 55364 (952)472-4541	ENG: *	ENG. BY *	GVU-12 NO2 MONITOR, FIELD WIRING	
	CONTR: *	DWN. BY CSS	* *	
A.	B.	SHEET *	DATE: 3/15/06	DWG. NO. SECTION 2 STD.
C.	D.			