

CO / CO₂ / NO₂ / OR VOC MONITOR VEHICLE EXHAUST GAS DETECTOR

MODEL GVU-1

GENERAL DESCRIPTION:

The GVU-1 ventilation control monitor combines toxic gas sensing and time-based fan control modes in an all solid-state, low maintenance, cost effective product.

The GVU-1 controller consists of the power supplies, solid state clocks, time delays, and output relays. It can continuously monitor one of the following Toxalert sensors: GVU-CO carbon monoxide sensor, GVU-CO₂ carbon dioxide sensor, GVU-NO₂ nitrogen dioxide sensor or GVU-VOC diesel smoke/air quality sensor. See last page for ordering information. (Please refer to applicable sensor data sheets).

TIME CONTROL:

The systems hourly timeclock outputs to the fan-on relay once per hour causing it to energize. The on time of the fan-on relay is user adjustable, in one minute increments from 1 to 8 minutes. The hourly timeclock operates in this manner irrespective of sensor reading, and may be disabled, if desired. To disable the hourly clock operation, place switch S3 to RST (RESET) position.

VENTILATION CONTROL:

Should a high toxic concentration occur (above user adjustable alarm level), a 30 second delay timer will start. Should the concentration persist through the delay period, the "alarm" clock is activated. The "on" time of this clock is user adjustable in discrete settings from 1 to 8 minutes and its setting is independent of the hourly clock setting. Upon activation of the "alarm" clock, the "fan-on" relay energizes and remains energized until the "alarm clock" times out. Should the concentration still be above the alarm level, the "fan-on" relay shall remain ON and the alarm relay shall energize. This condition is maintained until the concentration drops.

In the event of a power failure, the control unit sets itself to an alarm condition upon power restoration. Thus, fan activation is assured, clearing out any accumulated toxic gases.

FEATURES

- User adjustable alarm setting
- User adjustable minimum fan run time
- User adjustable 2nd stage activation
- Completely solid-state for long life
- Controller LED indicators for high concentration signal and fan on
- Operating range meets OSHA std. 1910.1000.
- UL listed upon request.
- Automatic fan start-up upon power restoration following power outage if desired.
- User adjustable clock activation of fans, if desired.
- NEMA 1 enclosure standard- others available.

OPTIONS

- Audible alarm with silence switch
- Fan on indicator
- Power on indicator
- High gas concentration indicator



GVU-1A

(Control unit w/ integral CO sensor)



Underwriters
Laboratories, Inc. ®
LISTED

SPECIFICATIONS

- **Automatic fan run upon power restoration**
- **Input power: 120VAC, 60 Hz, 1A (fused)**
- **Relay contacts: 24VAC, 2A resistive, 1.5A inductive**
- **Timers: 30 second delay on**
 Min. Fan Run Time 1-8 minutes
 Hourly Fan Run: 0-8 minutes

- **Enclosure:**
 Nema 1 standard, others available
 Dimensions: 12”H x 12”W x 4”D
 (305mm x 305mm x 102mm)
- **Finish:** Gray enamel
- **Weight:** 8 lbs. (3.6kg)

INSTALLATION INSTRUCTIONS

1. INTRODUCTION

Your TOXALERT ventilation control system incorporates the latest in solid state technology to give you maximum reliability and performance. The system alarm setpoint can be adjusted to activate fans upon detection of an unsafe gas concentration such as carbon monoxide, carbon dioxide, diesel smoke. In addition, a user definable hourly repeat cycle is provided, allowing time based, as well as concentration based fan activation. In both modes of fan control, the “on” time is user adjustable from 1 to 8 minutes in one minute increments. For optimum performance, install, burn-in, and check out your TOXALERT system exactly as instructed. If your TOXALERT can't be calibrated or fails checkout, please contact your local representative or TOXALERT International for servicing.

2. INSTALLATION

Locate a mounting location for the sensor away from direct fresh air intakes, exhaust and/or supply fans, and mount vertically on wall or support column normally 5 to 6 feet above floor (NO₂ and CO₂ sensor height may differ per application). Mount GVU-VOC sensor in ceiling. Refer to figs. 1, 2 and 3, to install and connect the TOXALERT control unit and sensors as following. (Please refer to job specific documentation for more detailed wiring options).

CONTROL UNIT-

- 1) Unlock and open enclosure cover.
- 2) If necessary, cut access holes for wiring in enclosure sides directly opposite terminal block TB2 and slightly below terminal block TB1. First, remove the four screws that secure chassis plate to enclosure and then carefully remove plate and attached circuit board; cut holes and remove metal chips from enclosure.
- 3) Mount enclosure with four screws.
- 4) Reinstall and secure chassis plate to enclosure with the four screws

SENSORS- Please refer to applicable sensor data sheets for mounting directions.

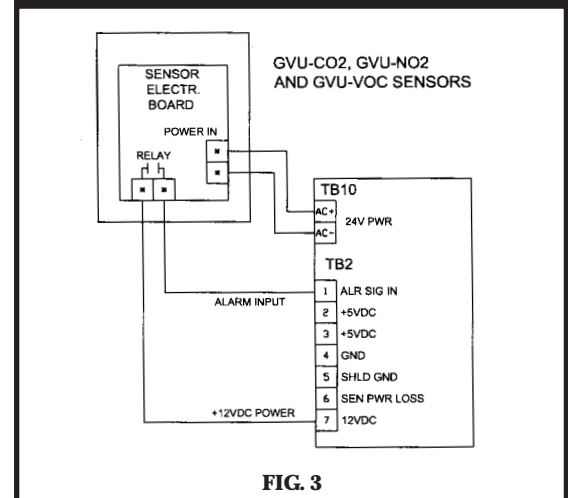
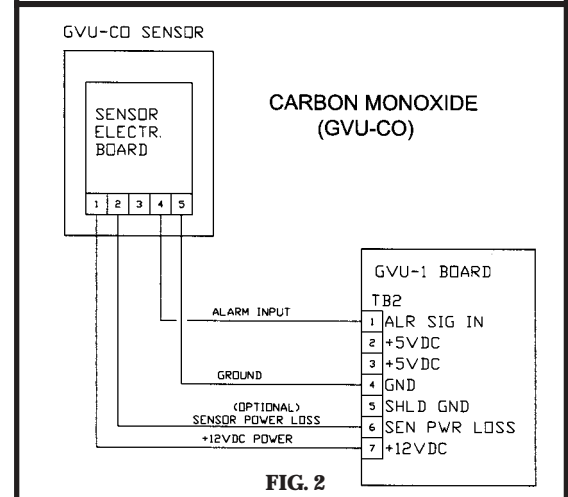
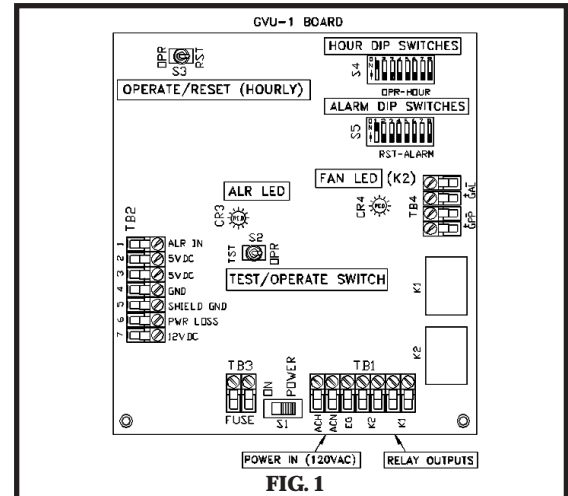

SENSOR WIRING

NOTE: Refer to figs. 2 and 3 and tables 1 and 2. Use shielded cable to interconnect sensing and control unit if metal conduit is not used, or if conduit also contains AC wiring.

NOTE: Comply with all local building codes and ordinances.

- 1) Measure distance between sensing unit and control unit and select proper size wire or larger wire from Table 1.
- 2) Run wiring between control and sensing unit and into enclosure through access holes. Connect wires from terminal blocks in sensing unit to TB2 in control unit per figs. 2 & 3.

TABLE 1

AWG	DO NOT EXCEED
#22 Wire	500 Ft. Sensor to Controller
#20 Wire	800 Ft. Sensor to Controller
#18 Wire	1300 Ft. Sensor to Controller
#16 Wire	2000 Ft. Sensor to Controller

TABLE 2

CONTROL UNIT TERMINALS

TB1-ACH	(AC Power in- 120 VAC HOT)
TB1-ACN	(AC Power in- 120VAC NEU)
TB1-EG	(Ground)
TB1-K2(2)	(Fan pilot relay contacts)
TB1-K1(2)	(Alarm relay contacts)
TB2-1	(Alarm input)
TB2-2	(Sensor power loss)
TB2-3	(+5VDC)
TB2-4	(+5VDC)
TB2-5	(Cable shield*)
TB2-6	(Power loss)
TB2-7	(+12VDC)
TB10	(24VAC or 24VDC+)
TB10	(24VAC or 24VDC-)

Terminal strip TB-2 (figs. 2 & 3) is the control I/O between the Gvu-1 control unit and the sensing unit. **(NOTE: This terminal strip will supply 12VDC power to the Gvu-CO SENSOR ONLY via terminal 7. Power for any other sensor type will be supplied at terminal strip TB-10).**

*Shielding of cable should be connected at only one end when grounded metallic conduit is not used, or shared with AC wiring. Connect shielding at terminal 5, TB-2 of control unit. Make sure shielding at sensor end is taped and isolated from any terminal or metal.

CONTROL UNIT WIRING

WARNING: To prevent fire or shock hazard turn off control unit and fan power sources before making connections to control unit. Comply with all local building codes and ordinances.

- 1) Connect power to TB-1 as follows:

AC hot to TB1-1 (ACH)

AC neutral to TB1-2 (ACN)

AC ground to TB1-3 (EG)

CAUTION: Relays K1 and K2 are rated for 2.0 amps resistive load. If a higher rated alarm or pilot control is required, add a remote relay between the control relay and load.

- 2) Connect dry contacts of alarm K1 (TB1-6 and TB1-7) to alarm device (optional).
- 3) Connect dry contacts of fan relay K2 (TB1-4 and TB1-5) to fan pilot control.
- 4) Set unit power switch S1 to the off position, TST/OPR switch S2 to OPR and OPR/RST switch to RST.
- 5) Turn on control unit AC power source, but do not apply power to fans at this time.

3. BURN-IN (GVU-CO & GVU-VOC SENSORS ONLY)

Burn-in allows sensor to stabilize before proceeding with alarm setting procedure.

- 1) Be sure fan power is off, power is applied to control unit and power switch S1 is set to PWRON.
- 2) Allow system to burn-in for a minimum of 72 hours with power turned on to sensor.
- 3) When 72 hours have elapsed, proceed with system check-out.

4. SETTING OF TIMING FUNCTIONS

There are two (2) eight position DIP switches in the upper right hand corner of the Gvu-1 control board, labeled S4 and S5. These control the systems timing functions.

Hourly Operations (S4)

S4 and toggle switch S3, in the upper left corner of the Gvu-1 board control the hourly operation of the K-2 relay. With the number "1" switch of S4 in the up position, the fan will run one minute each hour; with the number "2" switch in the up position, the system will run two minutes every hour; and so on, up to eight minutes. The switches are not additive and if more than one switch on S4 is in the up position, the system operates the lowest number of minutes of the S4 switches in the up position. With S3 in RST (reset) position, the hourly function is

deactivated. If S3 is in the OPR position and all S4 switches are down (off), K2 will operate 8 minutes each hour.

B) Minimum Fan Run Time (S5- Alarm setting)

Dip switch S5 controls the minimum time the K2 relay is activated once an alarm condition has been acknowledged by the controller. With number “1” switch of S5 in the up position, the minimum fan run time (K2 relay closed) is one minute. With number “2” switch of S5 in the up position, the minimum run time is 2 minutes, and so on, up to 8 minutes. The switches are not additive, and if more than one switch is in the up position, K2 operates the number of minutes of the lowest numbered switch of S5 in the up position. If all are in the down position, minimum run time defaults to 8 minutes.

5. ALARM SETTING PROCEDURES

All sensors are factory calibrated for their specific setpoints. Periodic calibration is required and performed at the sensor. Please refer to the individual sensor instruction manual (supplied with each sensor) and calibration instruction sheet (supplied with calibration kits, available separately). Annual sensor calibration check is recommended as a minimum.

6. CHECKOUT

Refer to figure 1 and table 2 to check out installation as follows:

- 1). Turn power off
- 2). Disconnect alarm input wires from sensors at TB2-1.
- 3). Set alarm timer (S5) to 2 minutes and hourly timer (S4) to 1 minute, and S2 to OPR.
- 4). Set power switch S1 to PWR ON. Set OPR/RST switch S3 to RST and back to OPR; note time.
- 5). Check that the LED indicators CR3 and CR4 and the fans are off.
- 6). Set TST/OPR switch S2 to TST, check that the CR3 LED indicator is ON. After 30 sec. check that CR4 LED and the fan(s) are on. Set S2 to OPR (CR3 off) and check that the fans stop running after 2 minutes. (CR4 off).
- 7). Set TST/OPR switch to TST, check that when 2 1/2 minutes have elapsed (this includes the delay) alarm device activates and fans continue to run. If optional alarm is not installed, connect an ohm meter across TB1-K1 and check that contacts of relay K1 are closed (continuity).
- 8). Set S2 to OPR. Check that fans stop and K1 deenergizes (CR3 and CR4 are off).
- 9). Check that 1 hour after step (4) was performed, fans start (CR4 lights) and run for 1 minute.
- 10). Set power switch S1 to off position, set alarm and hour timers to desired settings.
- 11). To disable hour clock operation, move switch S3 to RST position.
- 12). Reconnect sensor alarm input wire removed in step (2).
- 13). Set power switch S1 to PWR ON, Close and lock enclosure cover. This completes checkout and installation.

ORDERING INFORMATION

CONTROLLERS-

GVU-1/CO Control unit for use with remote carbon monoxide sensor (GVU-CO)
GVU-1/CO₂ Control unit for use with remote carbon dioxide sensor (GVU-CO₂)

GVU-1/NO₂ Control unit for use with remote nitrogen dioxide sensor (GVU-NO₂)

GVU-1/VOC Control unit for use with remote smoke/air quality sensor (GVU-VOC)

REMOTE SENSORS (Order separately)-

GVU-CO Remote carbon monoxide sensor
GVU-CO₂ Remote carbon dioxide sensor

GVU-VOC Remote smoke/air quality sensor
GVU-NO₂ Remote nitrogen dioxide sensor

GVU-1A Control unit with integral CO sensor
GVU-1B Control unit with integral CO₂ sensor

GVU-1C Control unit with integral VOC sensor
GVU-1D Control unit with integral NO₂ sensor

Options, such as additional relays, indicators, local or remote horns, etc. can be ordered along with control unit.)

GVU-1 Revised 5/05